



VS TUNERS



Catálogo de produtos

CAVACO, BANJO E UKULELÊ

Sobre a *VS Tuners*



Sua música feita à mão

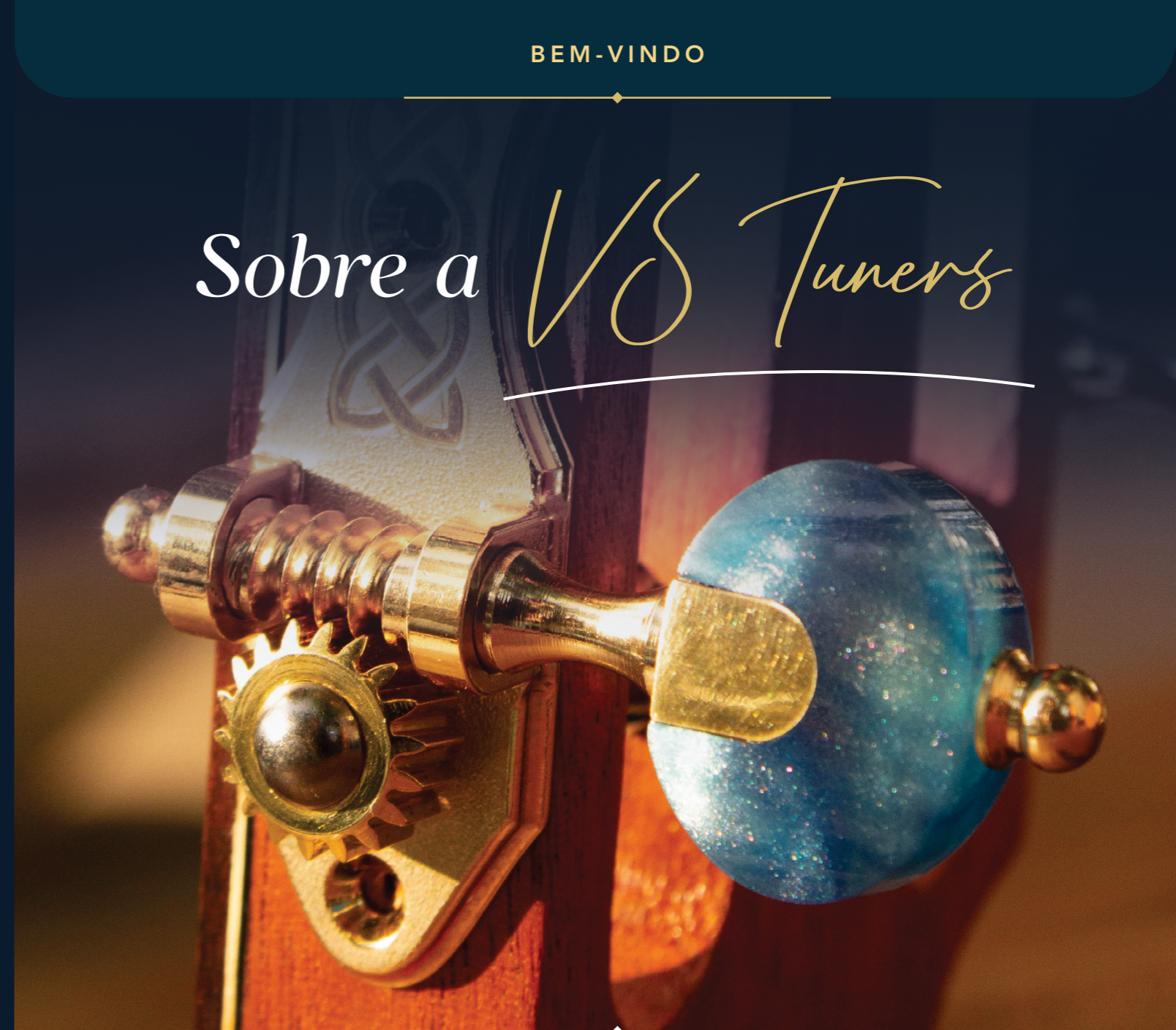

Somos a VS Tuners, uma empresa apaixonada por produzir tarraxas para instrumentos musicais, como Violão, Ukulele, Cavaquinho, Viola e Bandolim, para clientes que fazem da música sua profissão ou hobby. Oferecemos experiências únicas e exclusivas para todo o mundo, com produtos de excelência e tecnologia de ponta, que são produzidos de forma responsável, tanto social quanto ambientalmente.

Temos mais de **10 anos no segmento musical** com desenvolvimento e customização de tarraxas para diversos instrumentos como: violão, viola, ukulele, bandolim, cavaquinho e muito mais.

Com a tecnologia e qualidade das nossas tarraxas a afinação do seu instrumento se mantém por muito mais tempo do que com as tarraxas convencionais.

A tarraxa dos seus sonhos é possível com o nosso serviço de personalização. Temos diversas opções de botões, detalhes e materiais, tudo para você ter uma tarraxa **única**.



Os instrumentos

O banjo, ícone da música folclórica americana, destaca-se em bluegrass e folk, com cordas vibrantes e som brilhante. Com raízes portuguesas, o cavaco é suave e melodioso, essencial no samba e choro. Originado no Havaí, o ukulelê encanta com seu timbre doce, criando uma atmosfera descontraída e tropical.

Com as tarraxas produzidas pela VS Tuners todos esses instrumentos ganham um aumento em sua performance, **proporcionando uma experiência musical excepcional em todas as linhas de trabalho.**

Linhas • Cavaco, Banjo e Ukulelê

Solista — Maestro — Signature



VS TUNERS

	Linha Solista	Linha Maestro	Linha Signature	
	com restrições	sem restrições	do seu jeito	
O PRODUTO	Produto Brasileiro de alta performance e qualidade	✓	✓	✓
	Sistema de rolamento e mancal que permitem fluidez no ato de afinar o instrumento	✓	✓	✓
	Engrenagens com dezoito dentes, garantem a precisão e a sustentação na afinação	✓	✓	✓
	Pinos curvos para acomodação perfeita das cordas	✓	✓	✓
	Matéria prima com certificação	✓	✓	✓
	Custo-benefício superior aos produtos Americanos e Europeus	✓	✓	✓
ACABAMENTOS	CUSTOMIZAÇÕES			
	Botões em resina	✓	✓	✓
	Botões em madeira	✓	✓	✓
	Alumínio Brilhante	✓	✓	✓
	Alumínio Fosco	✓	✓	✓
	Alumínio Preto	✓	✓	✓
	Dourado	×	✓	✓
	Níquel	×	✓	✓
	Onix Brilhante	×	✓	✓
	Onix fosco	×	✓	✓
	Engraving personalizado em botão	×	✓	✓
	Engraving personalizado em plate	×	✓	✓
	Acetinado externo	×	✓	✓
Acetinado interno	×	✓	✓	
Projeto personalizado e exclusivo conforme seu instrumento	×	×	✓	



Linha Solista

CAVACO E BANJO

DESENHOS TÉCNICOS

VS_02 M3 PG

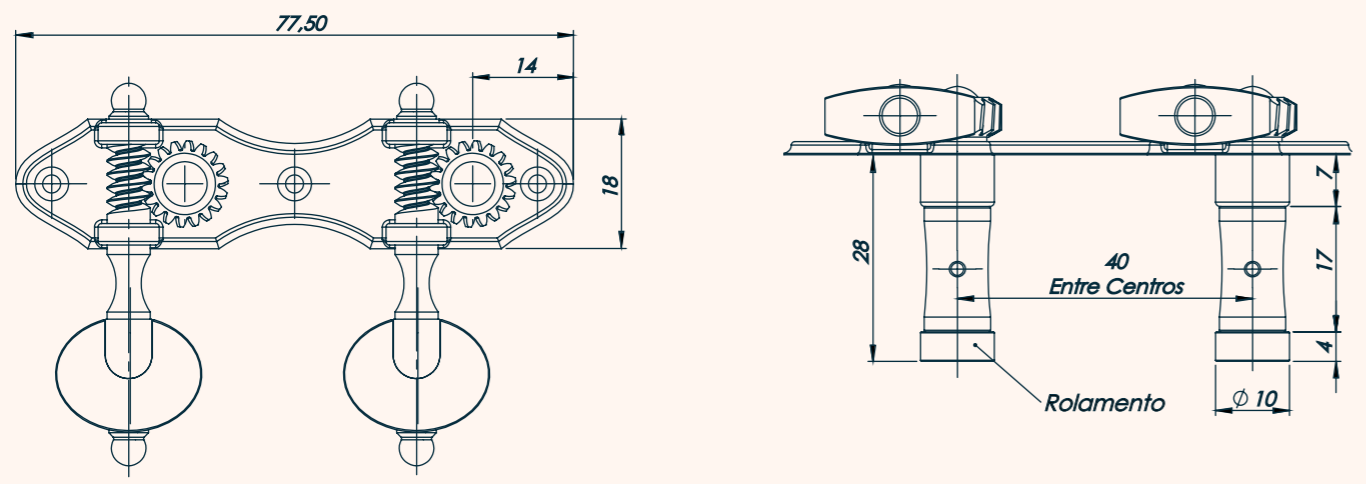

VS_02 M6 PG

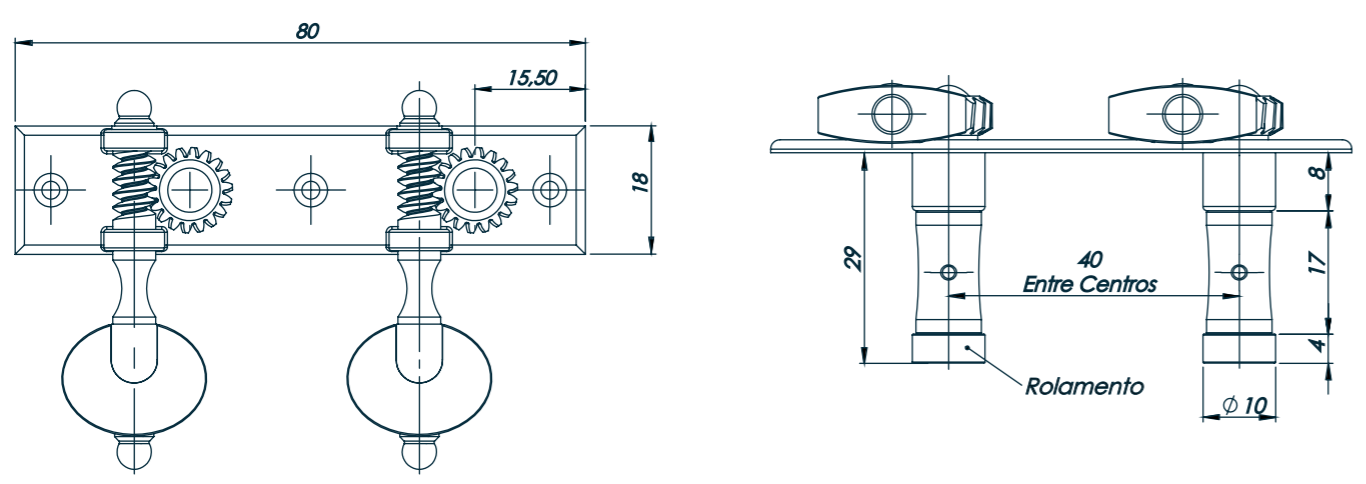

COMPONENTES ♦ LINHA SOLISTA

PINO GROSSO



SEM-FIM

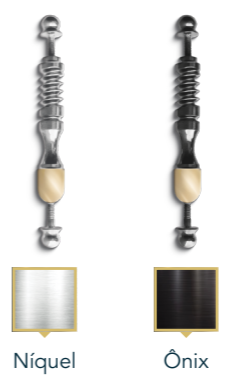

ENGRENAGEM

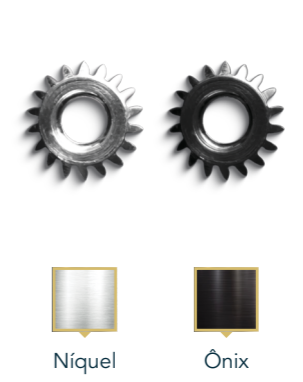

BOTÃO STANDARD



PLATES

M3



M6

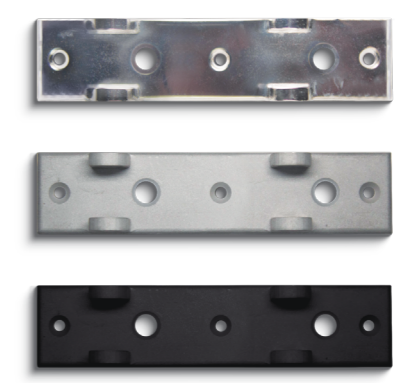

- BANHOS**
- Alumínio Brilhante
 - Alumínio Fosco
 - Alumínio Preto

Engravings Plate M3

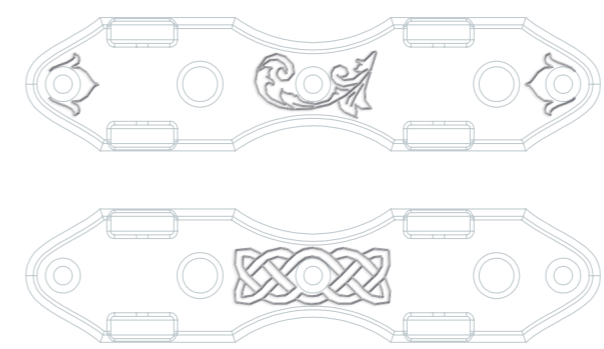

02M3E02

Obs.: todos os engravings da linha solista são prata.

02M3E03

Engravings Plate M6



02M6E32



Linha
Maestro

← CAVACO, BANJO E UKULELÊ

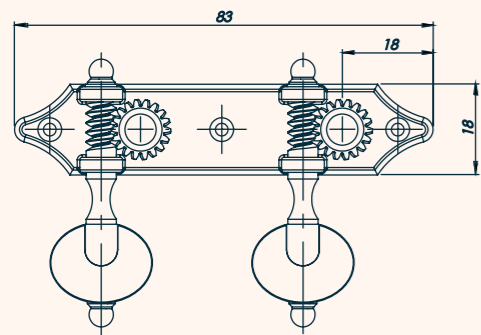

VS_02 M1 PG

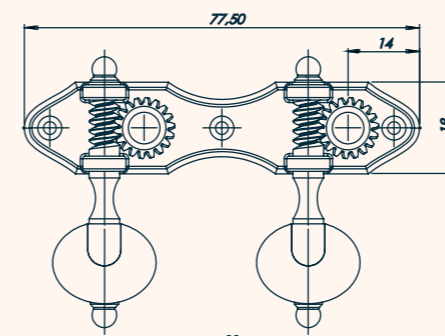
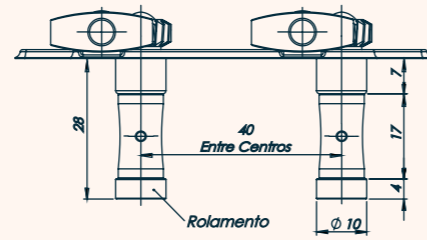

VS_02 M3 PFKL

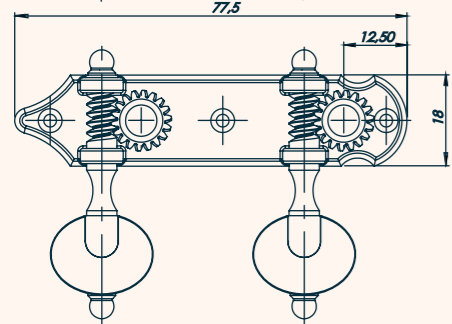
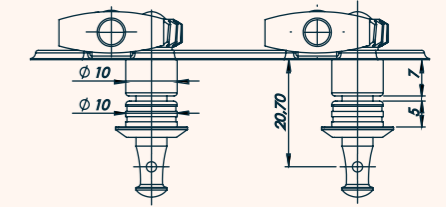

VS_02 M2 PG

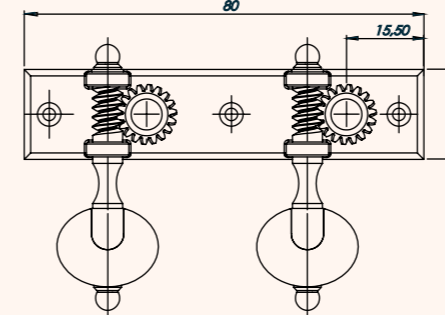
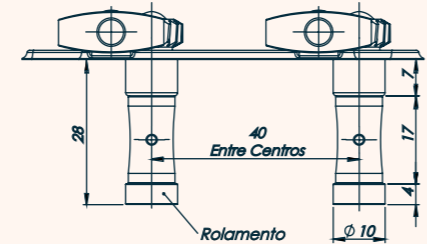

VS_02 M6 PFKL

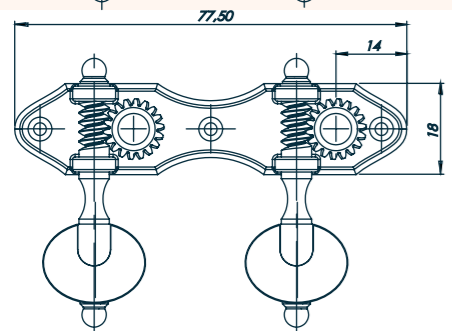
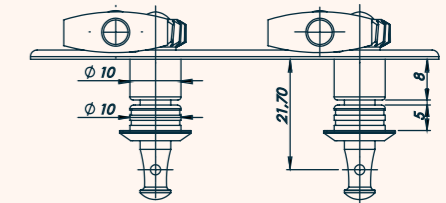

VS_02 M3 PG

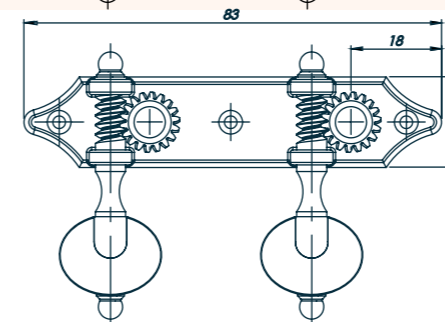
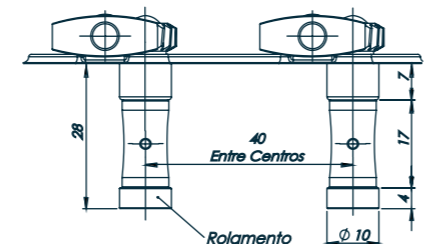

VS_02 M1 PF

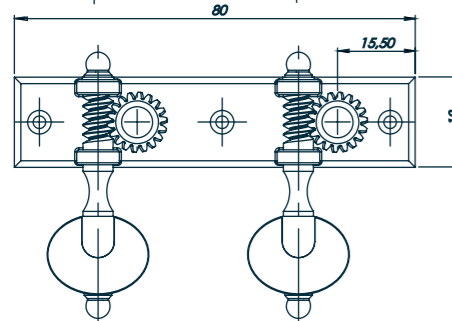
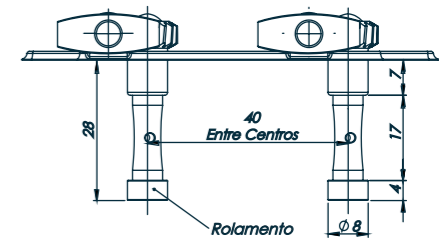

VS_02 M6 PG

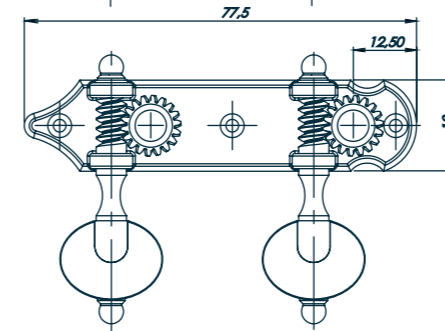
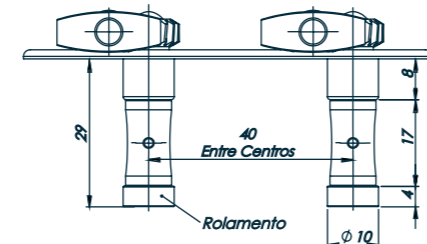

VS_02 M2 PF

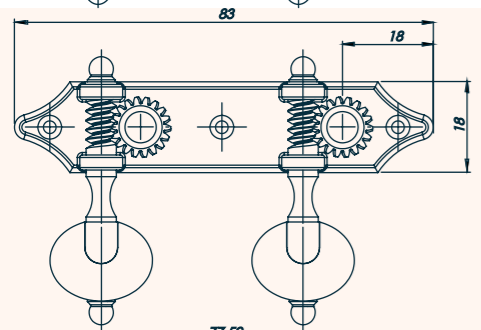
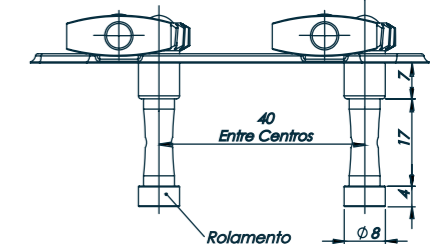

VS_02 M1 PFKL

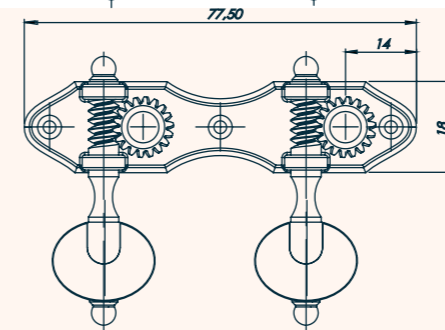
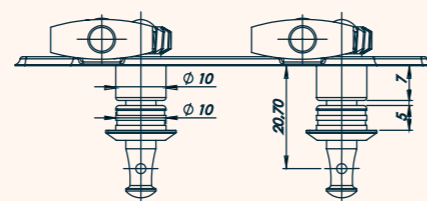

VS_02 M3 PF

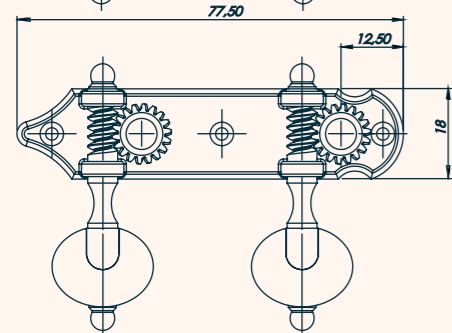
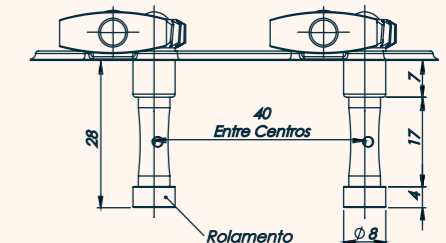

VS_02 M2 PFKL

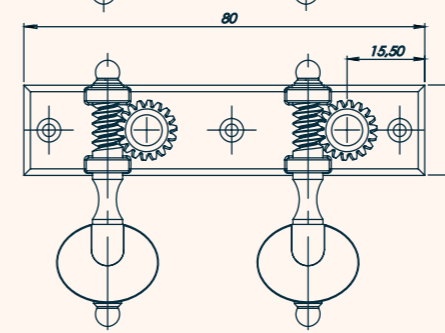
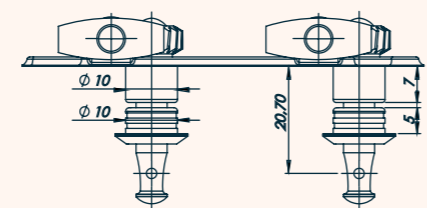

VS_02 M6 PF

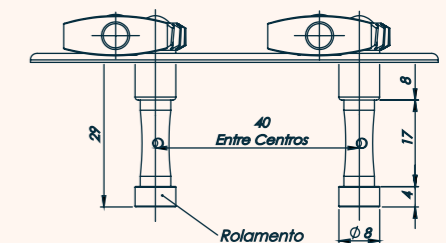

PINO GROSSO



PINO FOLK

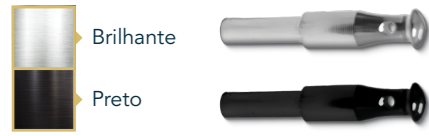

PINO FINO



SEM-FIM



ENGRENAGEM

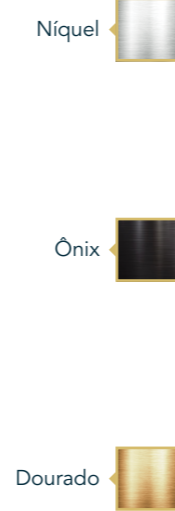

BOTÕES

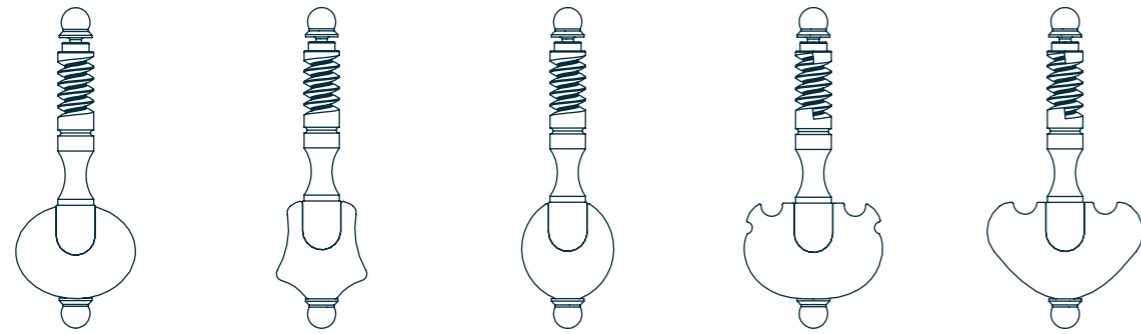

Standard Crown Mini Tenor Kidney

ACABAMENTOS DE BOTÕES





Engravings Plate M1

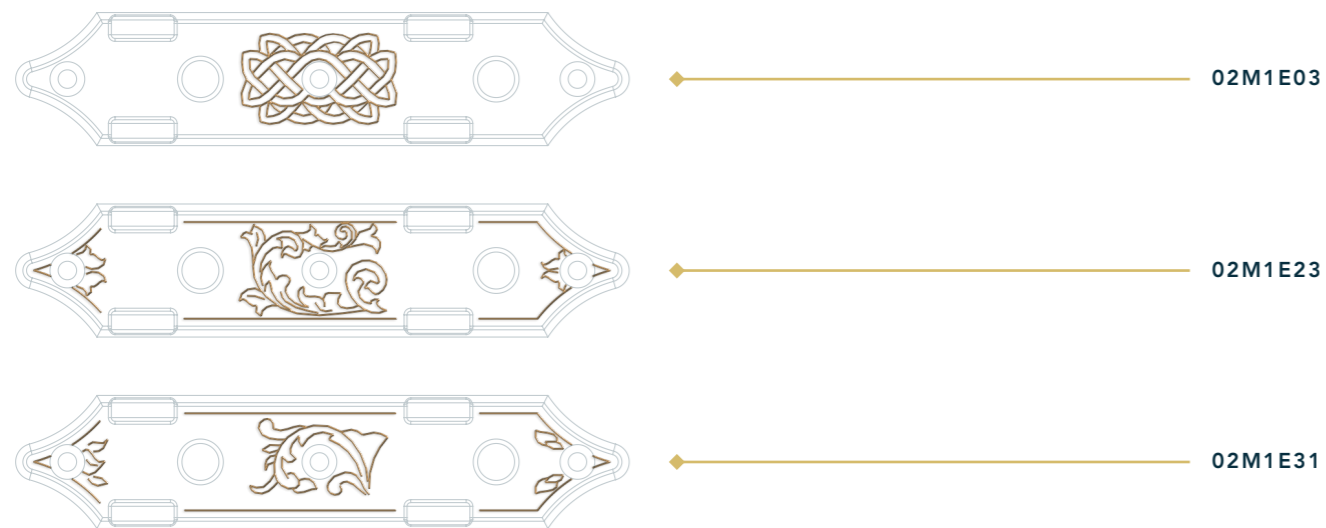

Engravings Plate M2

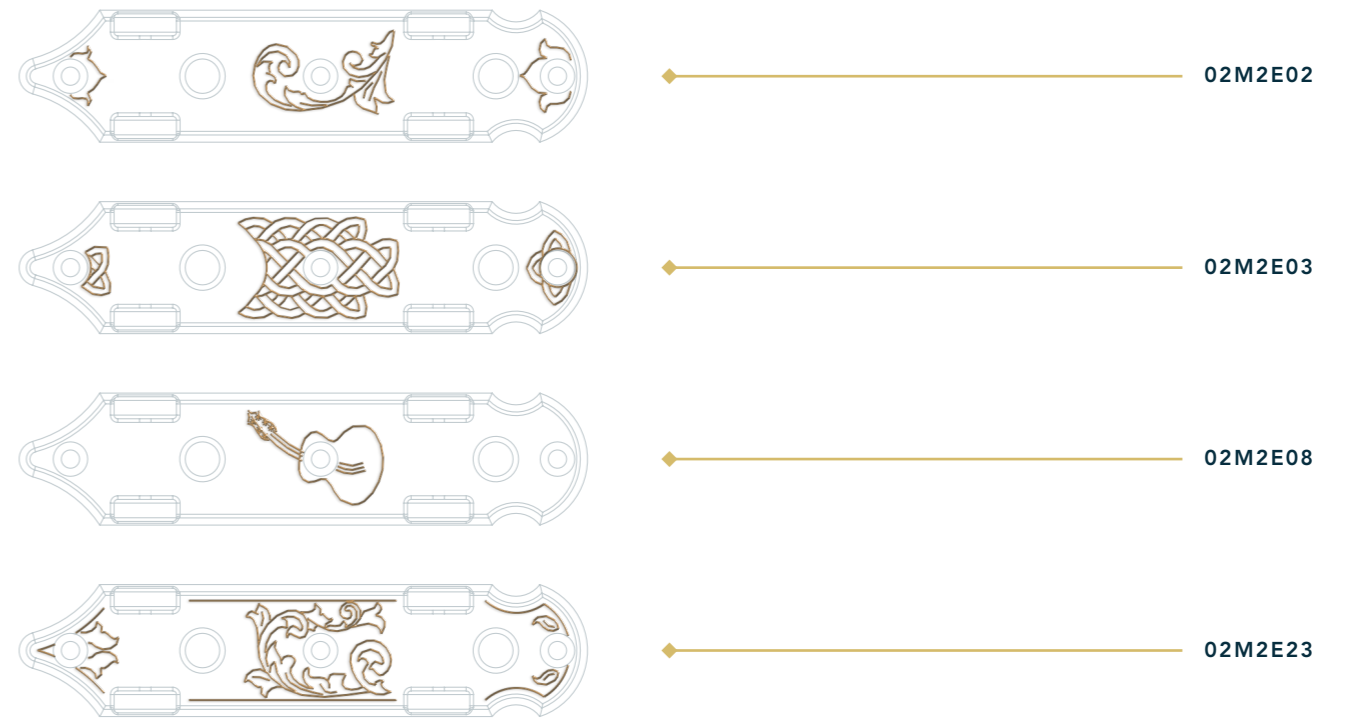

Engravings Plate M3

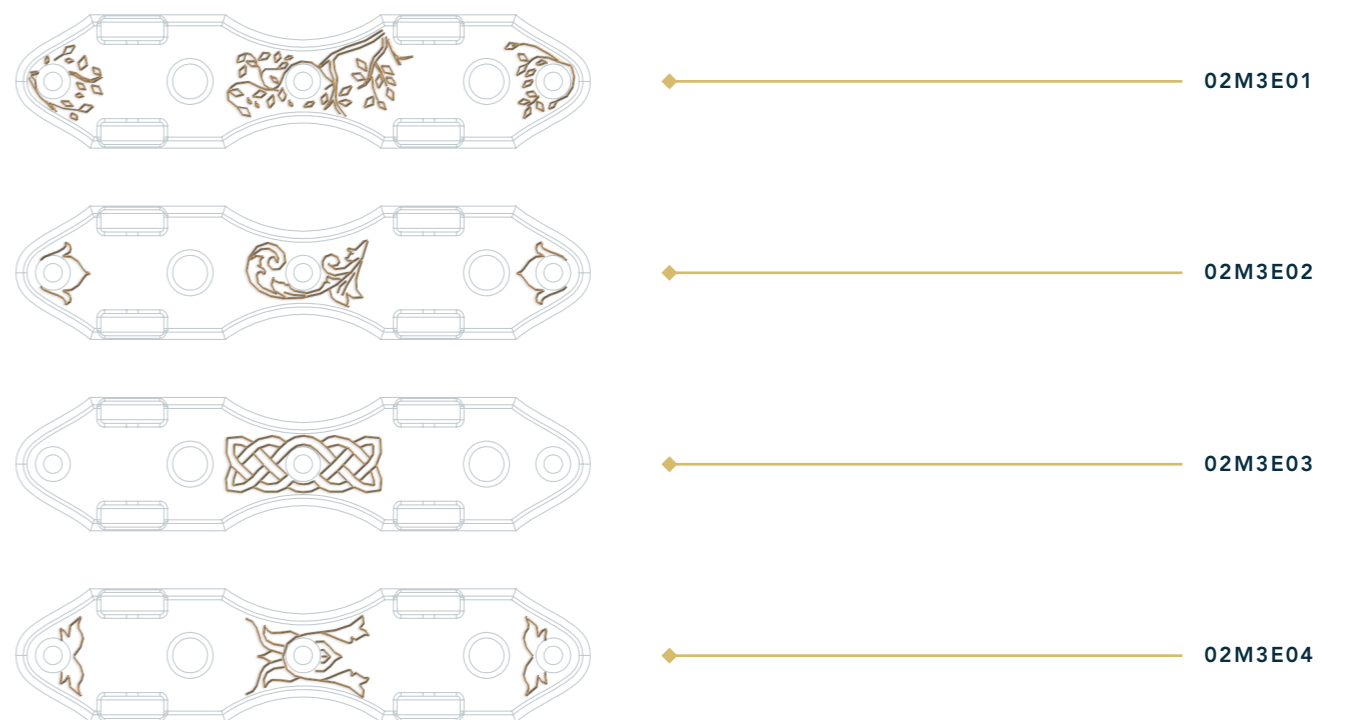

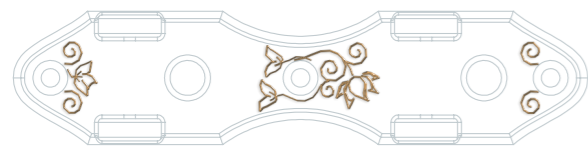

02M3E05



02M3E10



02M3E33

Engravings Plate M6



02M6E32



02M6EVS



◆ *Enobrecimentos Extras* ◆



Engraving Personalizado de Botão

Expresse-se ainda mais através de um engraving personalizado nos botões da sua tarraxa.

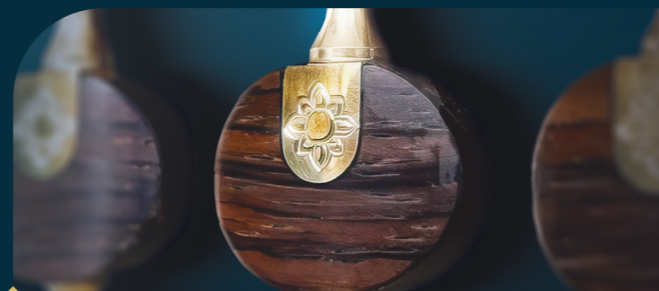

Engraving Personalizado de Plate

Transmita sua personalidade através de um engraving personalizado em seu plate.



Acetinado Interno

Dê um destaque a mais para o interior do seu engraving de escolha.

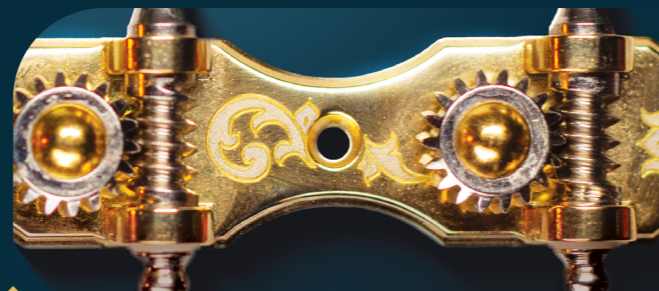

Acetinado Externo

Adicione um nível a mais de refinamento ao seu plate com o acetinado externo de engraving.



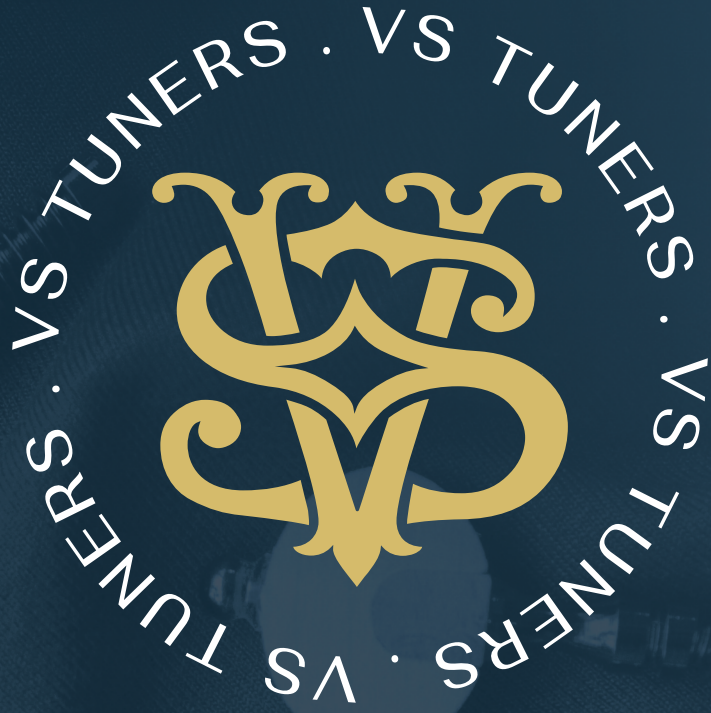

VSTUNERS.COM